



A.O. Smith Corporation

A. O. Smith Corporation

A. O. Smith Corporation is one of the world's leading manufacturers of residential and commercial water heating equipment, offering a comprehensive product line featuring the best-known brands in North America, China, and India.

The company was founded in 1874 in Milwaukee, Wisconsin where today the company is headquartered. A. O. Smith employs approximately 11,400 men and women at operations in the United States, Canada, Mexico, China, India, the United Kingdom, the Netherlands, and Turkey, which has the global reach to serve customers worldwide. We also have sales and distribution in more than 60 countries around the world.

As a global leader A. O. Smith and its employees pride themselves on applying innovative technology and energy-efficient solutions to products marketed worldwide. The company's goal is to be a leading global water technology company, and our focus is on building this platform through new product development, global expansion, strategic acquisitions and partnerships.

A. O. Smith India

A. O. Smith India was incorporated in 2006. Manufacturing facilities is set up in Harohalli, Bengaluru, India. After conducting extensive market research, a special range of water heaters have been developed for the Indian market. A. O. Smith inaugurated their manufacturing facility in their state-of-the-art factory in Harohalli, Bengaluru in June 2010.



REGISTERED OFFICE:

Manufactured by **A. O. Smith India Water Products Private Limited**
(formerly known as A. O. Smith India Water Heating Private Limited)

Plot No. 300, Phase - II, KIADB Industrial Area, Harohalli, Kanakapura Taluk, Ramanagara District, Karnataka – 562 112, India.
CIN: U31909KA2006PTC040282

HEAT PUMP WATER HEATERS



CONTENTS

HEAT PUMP WATER HEATERS

HPW-A	2
CAHP--80/120	
6/8/10/12(300L / 455L)	
CAHP--80/120	
HPI series	4
HPA-80	6
CAHP-1.5HP	8
CAHP-3HP	10
CAHP-10HP	11
KEY FEATURE OVERVIEW	12

How do heat pump water heaters work?

The technology inside the heat pump is similar to any domestic refrigerator, which uses a vapour compression cycle. The main components in the heat pump are the compressor, the expansion valve and two heat exchangers (an evaporator and a condenser).

1 Refrigerant in the evaporator is colder than the heat source. This causes the heat to move from the heat source (in this case the outside air) to the refrigerant, which then evaporates.

2 This vapour moves to the compressor and reaches a higher temperature and pressure.

3 The hot vapour now enters the condenser and gives off heat as it condenses.

4 The refrigerant then moves to the expansion valve; drops in temperature and pressure; and then returns to the evaporator.

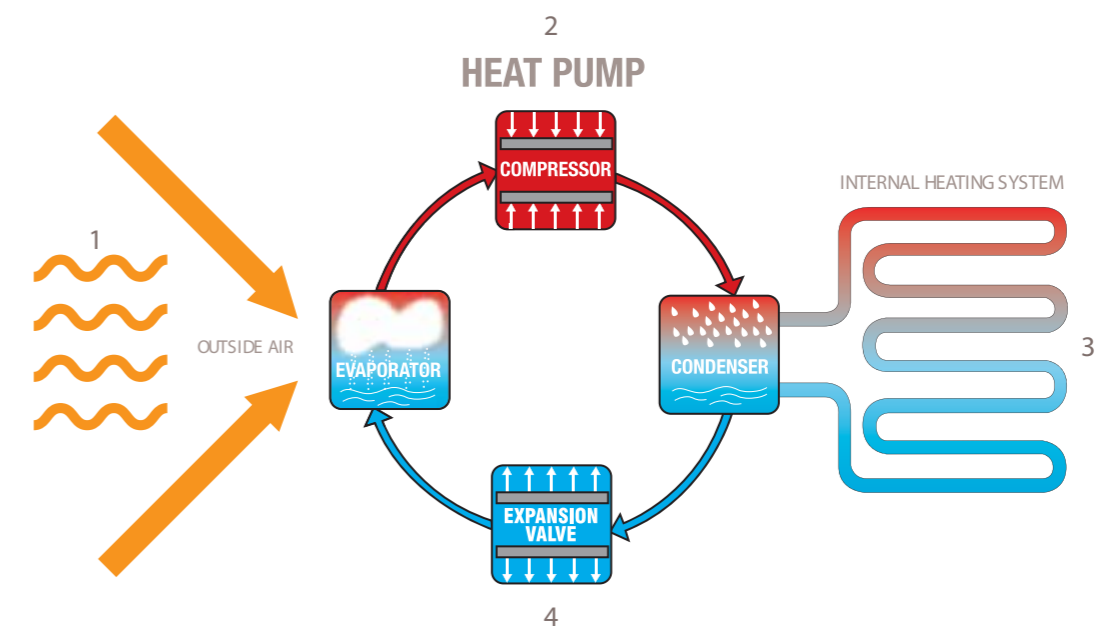

Benefits

- Reduced water heating costs upto 75 %
- Quick payback & return on investment
- Reliable hot water round the year
- Longest product life
- Reduced carbon emissions
- Silent operations
- Negligible maintenance costs

Common Applications

- Hotels
- Resorts
- Serviced Apartments
- Hospitals
- School & College Hostels
- Restaurants & Kitchen
- Laundry
- Industry

HPW Series

Features

- Heat pump water temperature 55°C, Max water temperature 75°C
- Input 200w, COP 2.6
- Two elements back up for quick recovery
- Patented AES energy saving system
- Timer setting
- Remote control
- PS safety system
- R134a Green refrigerant
- Wall mounted



Technical Specification

MODEL	HPW-60A2	HPW-80A2
Rated volume [L]	60	80
Rated voltage [V] / Rated frequency [Hz]	220 / 50	220 / 50
Rated input power [W] / Rated current [A]		
Efficiency mode	210 / 0.95	210 / 0.95
Hybrid Turbo mode	2200 / 10	2200 / 10
MAX mode	3000 / 13.7	3000 / 13.7
Heating Capacity [W]		
Efficiency mode	540	540
Hybrid Turbo mode	2540	2540
MAX mode	3000	3000
Inner tank rated pressure [MPa]	0.8	0.8
Range of water temperature [°C]	35-75	35-75
Environment range of energy-saving mode [°C]	10-44	10-44
Dimensions [A x B] [mm]	837 x 473	992 x 473
Net weight [kg]	42	45

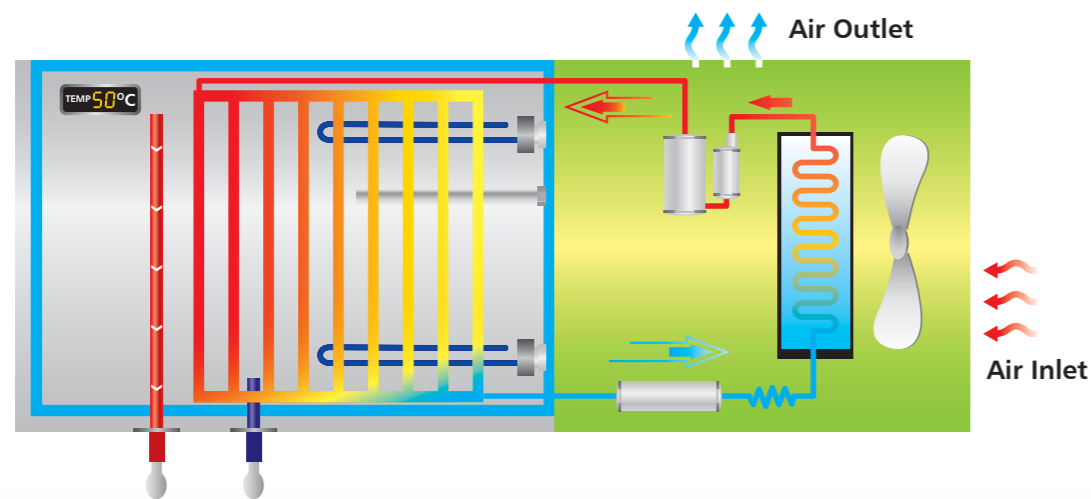
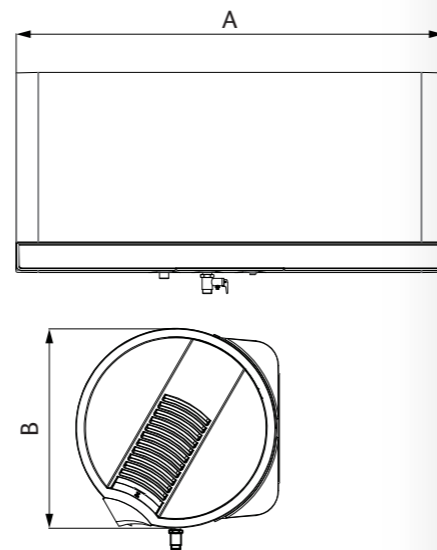

Touch Control and Remote Control

Convenience to access your water heater with Touch Control and Remote Control.

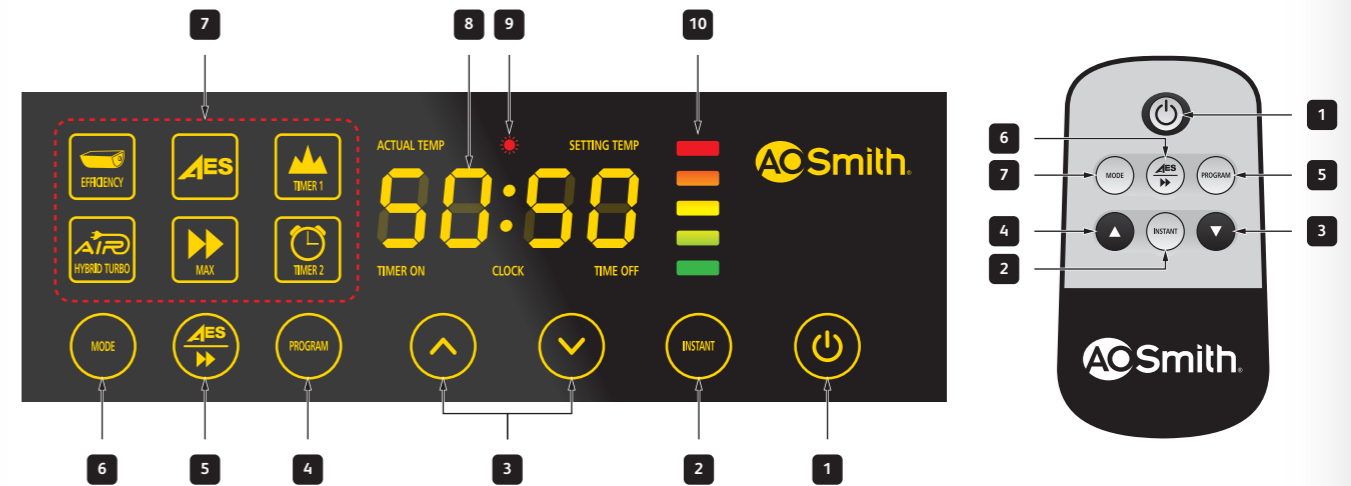

- 1 Power ON/OFF button:** Press Power ON/OFF button, the heater will be power-on. Setting temp and actual temp will be displayed a few seconds later.
- 2 Instant Heating button:** Users can select instant heating by pressing this button at all times and the water heater starts electrical heating immediately to reach the preset temperature. The heating is just one time.
- 3 Increase/Decrease button:** Press the Increase/Decrease button again to make the preset temperature increase or decrease by 1. And adjusting clock, timer also.
- 4 Program button:** Program is to set up clock, and timing for heating. Two timers is available.
- 5 AES/MAX button:** AES feature adopts heating cycles automatically, which will facilitate water usage and save energy by minimizing thermal loss. MAX function means more hot water output.
- 6 Mode button:** Change mode of Efficiency or Hybrid Turbo by touch Mode button.
- 7 Indicators:** This indicates the water heater is working in which mode, AES/MAX, timer, etc.,
- 8 Digital Indicators:** This indicates the water heater is working temperature, clock, timer setting, etc.,
- 9 Heating Indicator:** Indicator glows when the heating is in progress.
- 10 Display of hot water:** Five lighting blocks display the hot water distribution of different levels in the water tank of the water heater.



HPI Series

Features

- Heat pump water temperature 55°C, Max water temperature 75°C
- Heat pump input 500w, COP 3.8
- Two elements back up for quick recovery
- Patented AES energy saving system
- Timer setting
- Remote control
- PS safety system
- R134a Green refrigerant

Technical Specification

MODEL	HPI-40C1.0A	HPI-50C1.0A
Rated volume [L]	150	180
Voltage / Frequency [V/Hz]	220~ / 50	220~ / 50
Rated Input / Current [W/A]		
Efficiency	500 / 2.5	500 / 2.5
Hybrid Turbo	2500/11.5	2500/11.5
Output(W)		
Efficiency	1900	1900
Hybrid Turbo	3900	3900
Water temperature range [°C]	35~75	35~75
Ambient temperature range for Efficiency [°C]	7~43	7~43
Tank rated pressure (Mpa)	1.03	1.03
Dimension A [mm]	1530	1565
Diameter of Tank	Ø520	Ø520
Weight of Tank (kg)	89	98

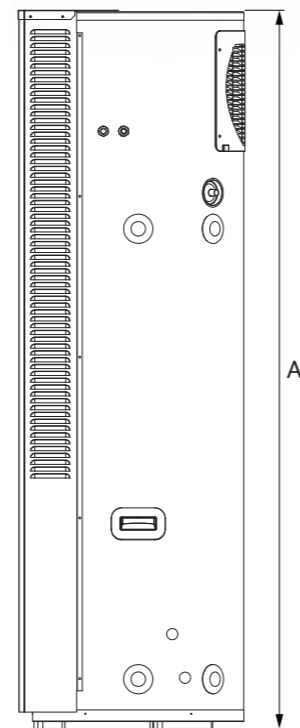

Wired Touch Control

Convenience to access your water heater with Wired Touch Control.

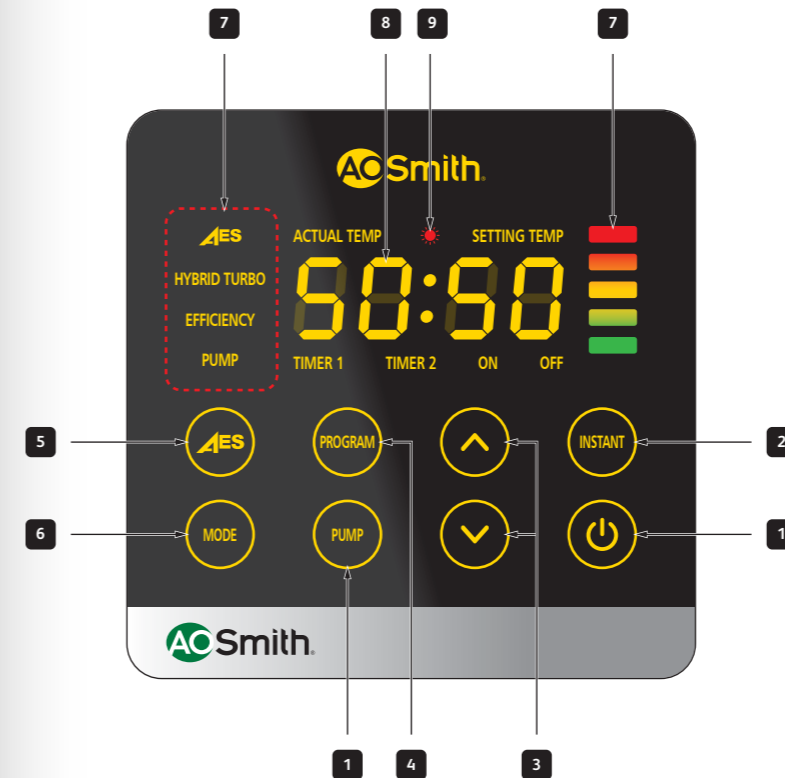

- 1 Power ON/OFF button:**
Press Power ON/OFF button, the heater will be power-on. Setting temp and actual temp will be displayed a few seconds later.
- 2 Instant Heating button:**
Users can select instant heating by pressing this button at all times and the water heater starts electrical heating immediately to reach the preset temperature. The heating is just one time.
- 3 Increase/Decrease button:**
Press the Increase/Decrease button again to make the preset temperature increase or decrease by 1. And adjusting clock, timer also.
- 4 Program button:**
Program is to set up clock, and timing for heating. Two timers is available.
- 5 AES button:**
AES feature adopts heating cycles automatically, which will facilitate water usage and save energy by minimizing thermal loss.
- 6 Mode button:**
Change mode of Efficiency or Hybrid Turbo by touch Mode button.
- 7 Indicators:**
This indicates the water heater is working in which mode, AES, timer, etc..
- 8 Digital Indicators:**
This indicates the water heater is working temperature, clock, timer setting, etc..
- 9 Heating Indicator:**
Indicator glows when the heating is in progress.
- 10 Display of hot water:**
Five lighting blocks display the hot water distribution of different levels in the water tank of the water heater.

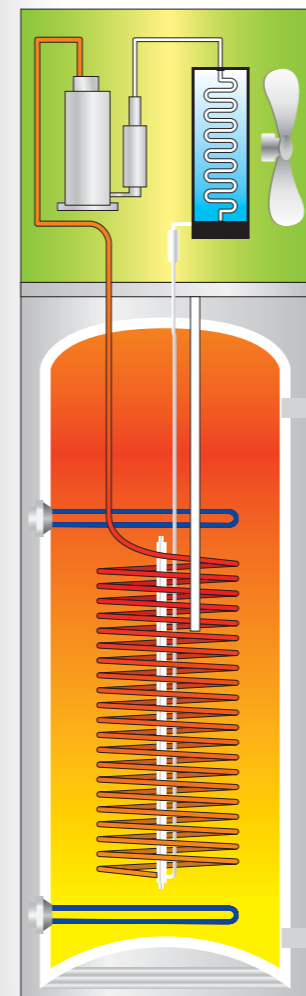

HPA-80 split type

Features

- Heat pump water temperature 55°C, Max water temperature 75°C
- Heat pump input 1010w, COP 3.6
- Two elements back up for quick recovery
- Patented AES energy saving system
- Timer setting
- Remote control
- R134a Green refrigerant

Technical Specification

MODEL	HPA-80C1.5A
Rated volume [L]	300
Voltage / Frequency [V/Hz]	220~ / 50
Rated Input / Current [W/A]	
Efficiency	1010/4.6
Hybrid Turbo	2010/9.1
Output(W)	
Efficiency	3640
Hybrid Turbo	4640
Water temperature range [°C]	35~75
Ambient temperature range for Efficiency [°C]	7~43
Tank rated pressure (Mpa)	1.03
External unit dimension	
A [mm]	560
B [mm]	320
C [mm]	835
Tank dimension	
A [mm]	Ø610
B [mm]	1640
Weight of external unit (kg)	56
Weight of tank (kg)	98

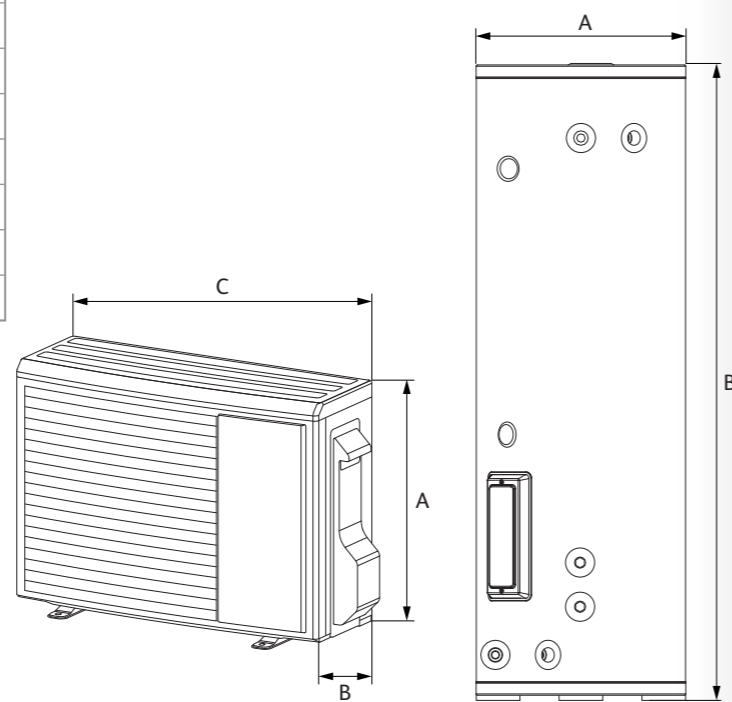

6

Wired Touch Control

Convenience to access your water heater with Wired Touch Control.

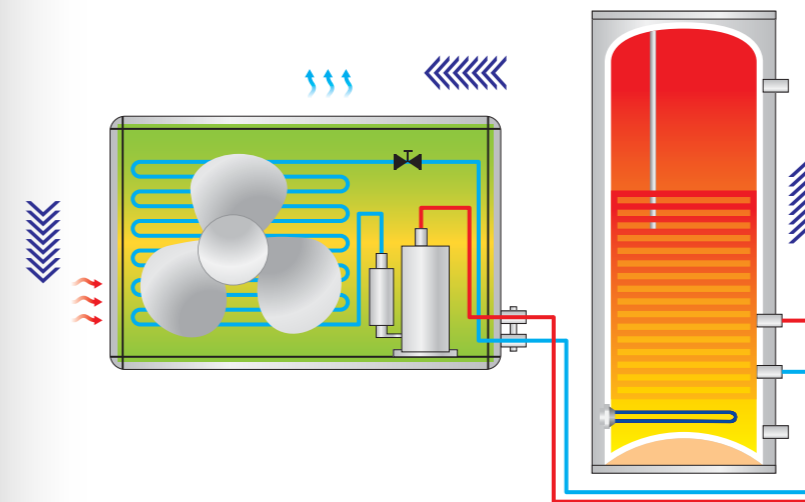
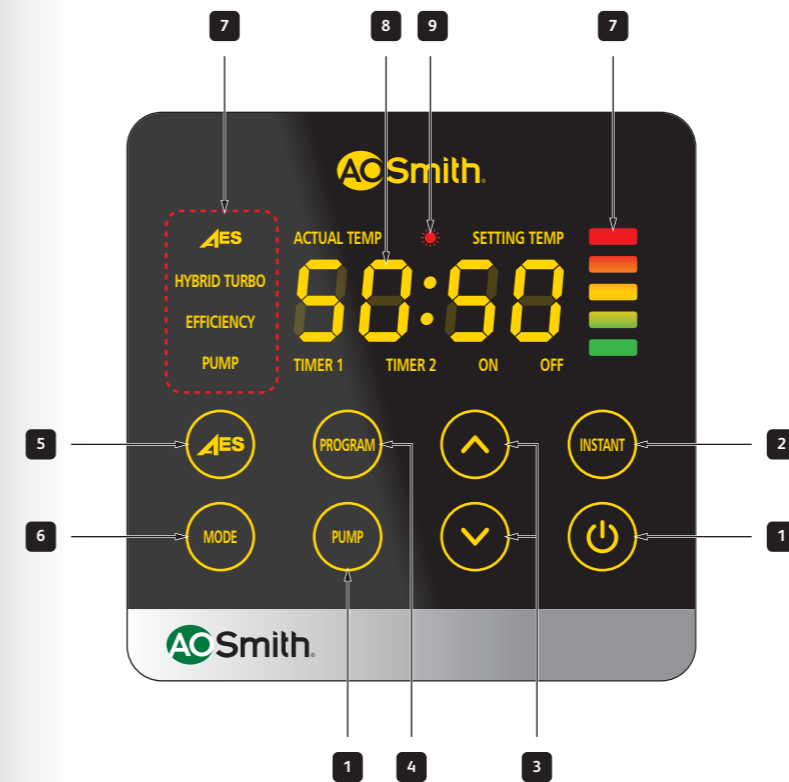

- Power ON/OFF button:** Press Power ON/OFF button, the heater will be power-on. Setting temp and actual temp will be displayed a few seconds later.
- Instant Heating button:** Users can select instant heating by pressing this button at all times and the water heater starts electrical heating immediately to reach the preset temperature. The heating is just one time.
- Increase/Decrease button:** Press the Increase/Decrease button again to make the preset temperature increase or decrease by 1. And adjusting clock, timer also.
- Program button:** Program is to set up clock, and timing for heating. Two timers is available.
- AES button:** AES feature adopts heating cycles automatically, which will facilitate water usage and save energy by minimizing thermal loss.
- Mode button:** Change mode of Efficiency or Hybrid Turbo by touch Mode button.
- Indicators:** This indicates the water heater is working in which mode, AES, timer, etc..
- Digital Indicators:** This indicates the water heater is working temperature, clock, timer setting, etc..
- Heating Indicator:** Indicator glows when the heating is in progress.
- Display of hot water:** Five lighting blocks display the hot water distribution of different levels in the water tank of the water heater.



7

CAHP-1.5HP

Features

- Unique heat exchanger design, heat pump water temperature to 65°C
- Energy saving, fast heating, electric back up and standard modes for choosing
- Smart control to avoid cold water mixing
- LCD display
- R134a green refrigerant
- Integrate design for outdoor installation
- Available in 300 & 450 Litre storage

Technical Specification

MODEL	CAHP-80 /120-6	CAHP-80 /120-12
Rated volume [CAHP-80 / CAHP-120] [L]	300 / 445	00 / 445
Rated voltage [V] / Rated frequency [Hz]	220 / 50	220 / 50
Rated power of heat pump (kW)	0.98	0.98
Rated heating capacity of heat pump (kW)	3.5	3.5
Electric heating power (kW)	6	12
Maximum input power (kW)	7.3	13.5
Maximum heat (kW)	9.5	15.5
Maximum current (A)	15.8	31.5
Maximum outlet water (°C)	65	65
Temperature control (°C)	35-82	35-82
Flow rate		
Energy saving mode (L/h)	73	73
Electric mode (L/h)	123	246
Hybrid/Rapid heat mode (L/h)	196	319
External unit dimension		
A [mm]	1670/1700	670/1700
B [mm]	910/991	910/991
C [mm]	503/503	503/503
D [mm]	Ø610/711	Ø610/711
Net weight [CAHP-80 / CAHP-120] (Kg)	165 / 220	165 / 220

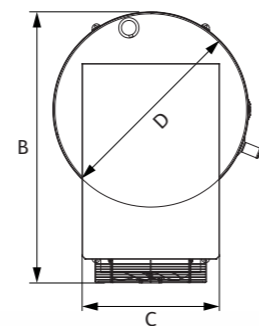
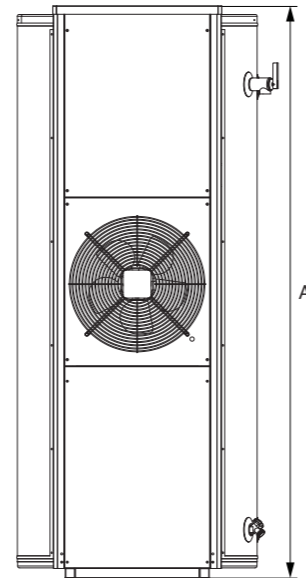

Wired Remote Control

Convenience to access your water heater with Wired Touch Control.



- Two Operation Mode could be set by controller.
 - High Demand Mode: Water heater uses heat pump and electric heating when the working condition is in heat pump operation range, otherwise water heater only uses electric heating.
 - Efficiency Mode: Water heater only uses heat pump heating when the working condition is in heat pump operation range, otherwise water heater changes to electric heating automatically.
- Display current status and error information.
- Circulation pump control mode.
- Smart Mode: According to water temperature, ambient temperature and other conditions, calculate automatically to control water pump running hour and interval hour, save electricity intelligently.
- Fixed Mode: Manual input water pump running hour and interval hour.
- LCD Display Panel
- Children lock can prevent child from changing water heater settings.
- 2 section timing heating.

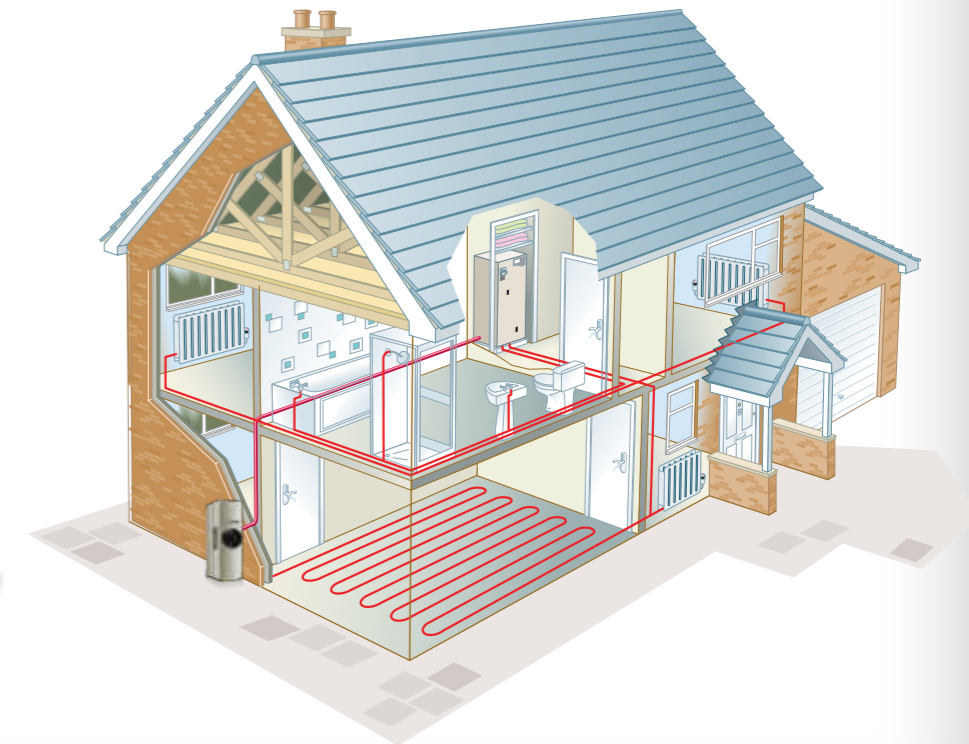

CAHP-3HP

Features

- Unique heat exchanger design, heat pump water temperature to 65°C
- Energy saving, fast heating, electric back up and standard modes for choosing
- Smart control to avoid cold water mixing
- LCD display
- R134a green refrigerant
- Integrate design for outdoor installation

Technical Specification

MODEL	CAHP-120C-12
Rated volume [L]	430
Rated voltage [V] / Rated frequency [Hz]	220 / 50
Rated power of heat pump (kW)	2.25
Rated heating capacity of heat pump (kW)	8.5
Electric heating power (kW)	12
Maximum input power (kW)	15.1
Maximum heat (kW)	20
Maximum current (A)	380V/3N/50Hz 31.5
	220V/1N/50Hz 78.5
Maximum outlet water (°C)	65
Temperature control (°C)	35-82
Flow rate	
Efficiency/Standard Mode (L/h)	182
High Demand/Winter Mode (L/h)	439
External unit dimension	
A [mm]	1770
B [mm]	1002
C [mm]	600
D [mm]	Ø711
Net weight [CAHP-120] (Kg)	264

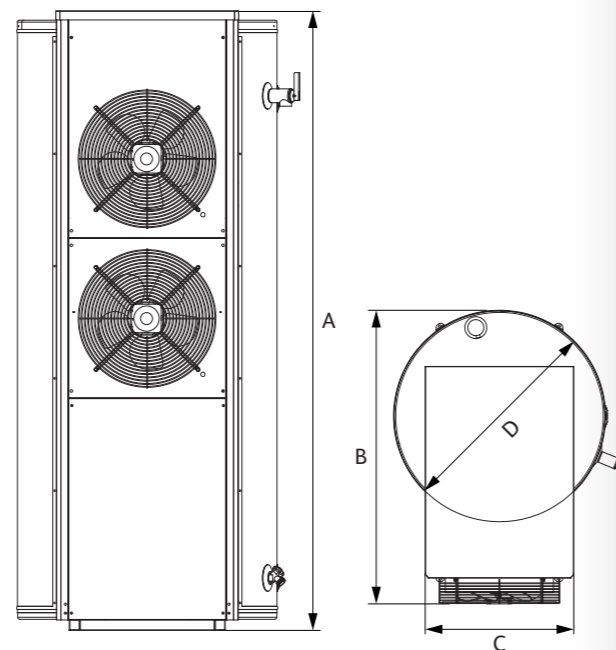

Wired Touch Control

Convenience to access your water heater with Wired Touch Control.



- Two Operation Mode could be set by controller.
 - High Demand Mode: Water heater uses heat pump and electric heating when the working condition is in heat pump operation range, otherwise water heater only uses electric heating.
 - Efficiency Mode: Water heater only uses heat pump heating when the working condition is in heat pump operation range, otherwise water heater changes to electric heating automatically.
- Display current status and error information.
- Circulation pump control mode.
 - Smart Mode: According to water temperature, ambient temperature and other conditions, calculate automatically to control water pump running hour and interval hour, save electricity intelligently.
 - Fixed Mode: Manual input water pump running hour and interval hour.
- LCD Display Panel
- Children lock can prevent child from changing water heater settings.
- 2 section timing heating.

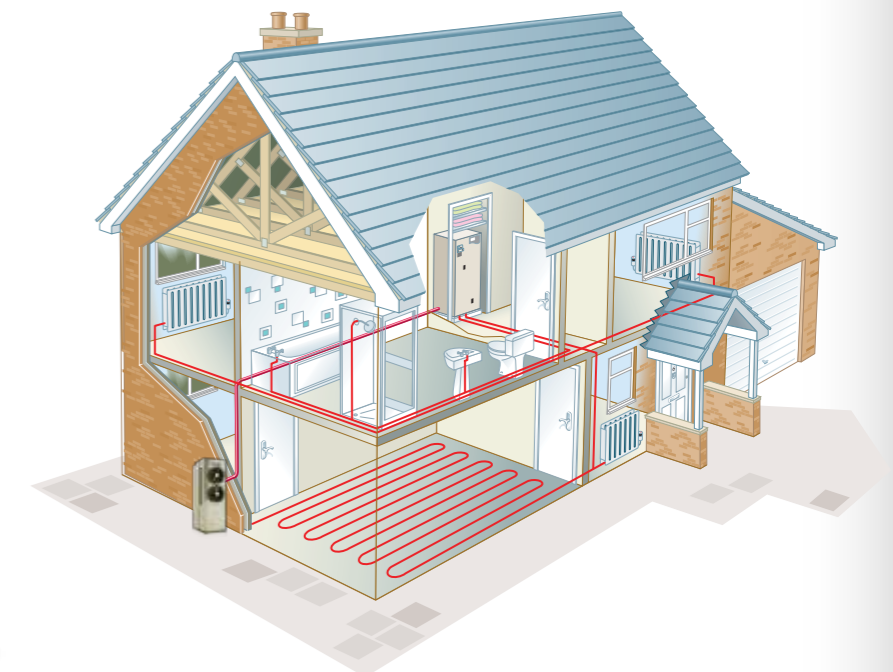

CAHP-10HP

Features

- Smart control to avoid cold water mixing
- Energy Saving
- Power Off memory
- Auxiliary heater
- Refrigerant: R410

Technical Specification

MODEL	CAHP-MC-38
Power Supply	380V 3N ~ 50hz
Voltage Range	380V +/- 10 %
Rated Water Flow ⁽¹⁾	6.5 CMH
Rated Power Input ⁽¹⁾	10.3 kW
Rated Operation Current ⁽¹⁾	18.6 A
Max. Power Input	13.2 kW
Max. Operation Current	23.3 A
Operation Noise ⁽²⁾	65 dB(A)
Refrigerant / Quantity	R410a / 6.2Kg
Refrigerant Side Design Pressure	
High Side	4.2 Mpa
Low Side	3.1 Mpa
Water Side Design Pressure	1.0 Mpa
Water Side Pressure Drop ⁽³⁾	45 Kpa
Water Connection Size	DN40 (R1 1/2")
Waterproof Class	1Px4
Net Weight	287 Kg



Note:

- (1) Rated condition: Ambient temperature 20/15 (dry/wet bulb), water temperature 47/52 (inlet/outlet).
- (2) Sound pressure value at one meter.
- (3) Measured at the rated water flow.

Power off memory

- The central controller stores the status of the units automatically when the heat pump units or the central controller is powered off. The central controller will send the command to the system to operate as the status before the power off when the power supply recovers. This will allow the system operate as per the previous setting during abnormal power off.

Auxiliary heaters

- The heat pump heating capacity will decrease when the ambient temperature decreases. Auxiliary heaters should be equipped to improve the heating capacity and ensure the hot water supply if the minimum ambient temperature is lower than 10 Celsius. Either electric heater or gas heater could be used as auxiliary heater.
- The central controller supplied by A.O. Smith provides control signal to the auxiliary heater to optimize the system operation efficiency. For example, if a gas heater is selected as auxiliary heater, the central controller will control the heat pump units and the gas storage heater based on the actual ambient temperature, water temperature and the database stored in the CCB to achieve the most economic operation cost, as well as the most reliable operation.

